

KOKER

NOTICE: - TO
INSTALLERS
INSTRUCTIONS
MUST BE
GIVEN TO
HOMEOWNER

Koker with Thermostat

KEYSTOKER KOKER—THERMOSTAT—INSTALLATION INSTRUCTIONS

Select a position on a solid level surface with direct access to chimney. On non-masonry floors, use an approved fireproof protector under furnace. Maintain 16" clearance to combustibles from side walls. Clearance to rear is 18". Clearance to hopper end is 2'.

Plumb hopper end of Koker furnace with level.

Install fan and filter brackets.

Wire fan into 2" x 4" box.

Install coal hopper and bend down small flange into throat of stoker unit.

Install barometric damper in first section of stove pipe. Connect stove pipe from chimney to stove with 24 gauge, 6" pipe. Secure with metal screws.

Mount thermostat according to instructions packed with it. Use thermostat wire to connect to terminals in RA89 Relay marked T.T. Be sure to securely snug the captive screws in thermostat to the plastic wall plate.

Before starting initial fire, adjust combustion air shutter to approximately 50% open. (See # 4 under Pusher Bar)

Plug into grounded wall receptacle.

Cleaning and Lubrication...stove pipe should be cleaned once during heating season. Check exhaust tubes in Koker and clean with brush. Keep base of interior of stove clean.

Remove flyash from under grate annually by removing combustion motor from stoker unit and vacuuming out fly ash. Or, by removing grates, by taking out bolts at bottom of grates and vacuuming. Re-cement grates in place with furnace cement.

To minimize corrosion of your stove and accessories, it is important to clean furnace thoroughly at end of heating season.

Oil hinges and door handles before summer shut down. Check chimney and base of chimney for obstructions. Oil combustion motor and convection blower motor with a light grade of S.A.E. motor oil.

KOKER with THERMOSTAT

FAN LIMIT SWITCH

1. Hi limit pointer – shuts stoker unit off when internal air temperature reaches 200 degrees. (do not change setting)
2. Center pointer – Turns convection blower on when internal air Temperature rises to this setting. (may be adjusted)
3. Low limit pointer – Turns convection blower off when internal air Temperature falls to this setting. (may be adjusted)
4. Records current internal temperature with corresponding number On dial.
5. White button – pull out for automatic operation of convection Blower. Push in for constant running of convection blower.

HONEYWELL RELAY

Terminals 1 & 2 - power supply to relay. Terminal #4 – power Supply to stoker unit. Terminals T. T. – for wire to thermostat

TIMER

Operation and adjustment procedures are located on inside hinged cover of timer. Chimney drafts vary and timer settings are not always able to be accurately preset from factory.

Purpose of timer is to maintain a fire during periods of no demand from thermostat. Timer must turn on combustion and/or feed motor as often as necessary to prevent fire from being extinguished. Timer will be preset to run approximately one minute on and about ten minutes off. If timer is unable to maintain fire at this setting, more trippers may be added to increase running time. If fire remains lit, and produces too much heat, slowly reduce the number of trippers in timer.

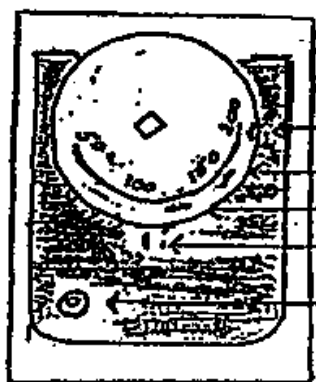

FAN LIMIT SWITCH

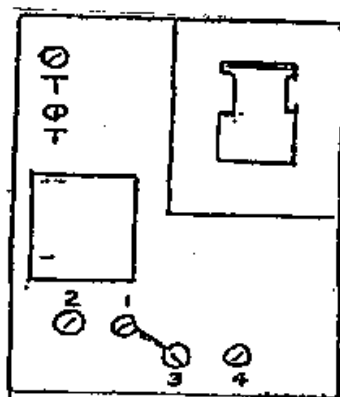

HONEYWELL RELAY

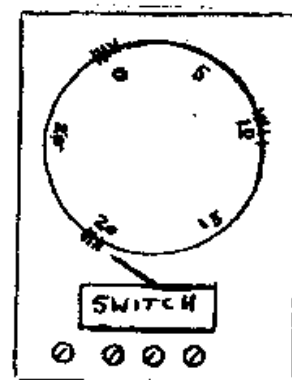

TIMER

PUSHER BAR Activated by cam on gear motor to force coal from hopper onto grate, forcing ashes to fall into ash pan. Length of stroke is adjustable.

#1 on Diagram. White coal feed adjustment nut – Turn clockwise for more coal feed. Turn counter clockwise for less coal feed.

#2 on Diagram. Nylon adjusting screws. To eliminate too much side to side play, and to prevent metal to metal contact during feeding process.

#3 on Diagram. Nylon cam – located on Gear Motor. To give reciprocating movement to pusher bar.

#4 on Diagram. Air Shutter – located on Combustion Motor.

GEAR MOTOR. The drive shaft turns approximately 1 RPM. The nylon cam on drive shaft will, when moving inward, force coal down from coal hopper onto grate. When withdrawing will allow coal to fall in front of pusher bar for next inward stroke.

COMBUSTION MOTOR. Forces air through holes in grate to burn coal hotter and faster. Most combustion motors are equipped with an adjustable air shutter for regulating air flow through fire during running cycles. (Hearth and smaller Units not equipped with air shutter.)

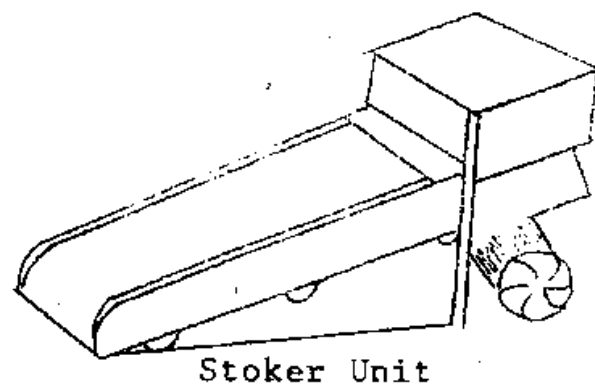
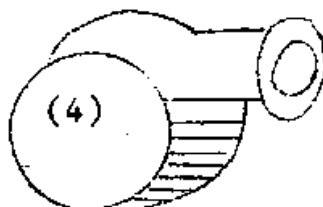
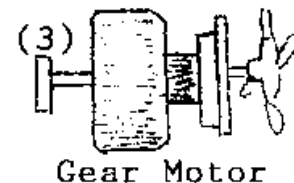
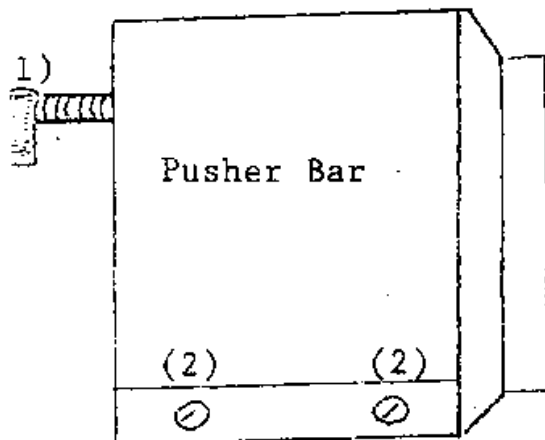

KOKER with THERMOSTAT

CONVECTION BLOWER – takes cool air from room, forces it through heated air chambers and returns heated air into room. It is activated by the fan limit switch

THERMOSTAT- Top pointer is desired room temperature. Bottom pointer is thermometer. When room temperature drops below setting, combustion and/or feed motor will start. As fire is burning, internal air temperature of stove will rise. When stove temperature reaches setting of center pointer in fan limit switch, convection blower will start. Temperature in home will now begin to rise. When temperature reaches setting on room thermostat, the combustion and/or feed motor will shut off. The convection blower will continue to run until furnace cools.

STARTING FIRE – plug power cord in. Turn room thermostat higher than temperature in home. Gear motor and combustion motor should run. Find coal feed adjuster (painted white) on stoker unit, and while it is withdrawing, (moving toward you) turn nut counter-clockwise as far as it will go. Use finger only. Do not use a wrench on the feed adjuster nut. Pull power cord from outlet. Fill hopper, slide coal down onto grate, covering entire grate. Place kindling about in center of grate. Light kindling, and plug cord in. When kindling is burning well, throw a few hands full of coal onto fire. After fire is established, turn coal feed adjuster in about 8 full turns, (clockwise) Remember, make coal feed adjustment with finger only, while pusher is moving toward you. Further coal feed adjustment should be made, so that when stoker unit is running to satisfy thermostat, you should have a full grate of fire, except for the last two inches of grate, which should be ash. To fine tune the coal feed, turn the white feed adjuster nut clock-wise for more coal feed, or counter-clock wise for less coal feed. Turn adjuster nut one or two full turns per day, until best results are obtained. When thermostat is not calling for heat, red fire bed should be approximately 2" to 3". It is usually not necessary to readjust coal feed to start another fire.

DRAFT CHECK – after starting fire, when stove pipe and chimney get warm enough to check draft with a draft gauge. If no draft gauge is available:

Open ash door slightly and check with a lit match. The flame of match must be drawn into stove when combustion motor is running. If not:

- A. Be sure chimney is clean.
- B. Close combustion air shutter gradually, while still checking draft with a lit match. When flame from match is drawn into stove, combustion air shutter is now set.

CLEANING GLASS – For best results, clean glass daily with non-abrasive cleaner. Turn stove off...allow glass to cool...apply cleaner...wipe off with paper towels...dampen a clean paper towel with water and wipe glass again.

Koker w/Thermostat

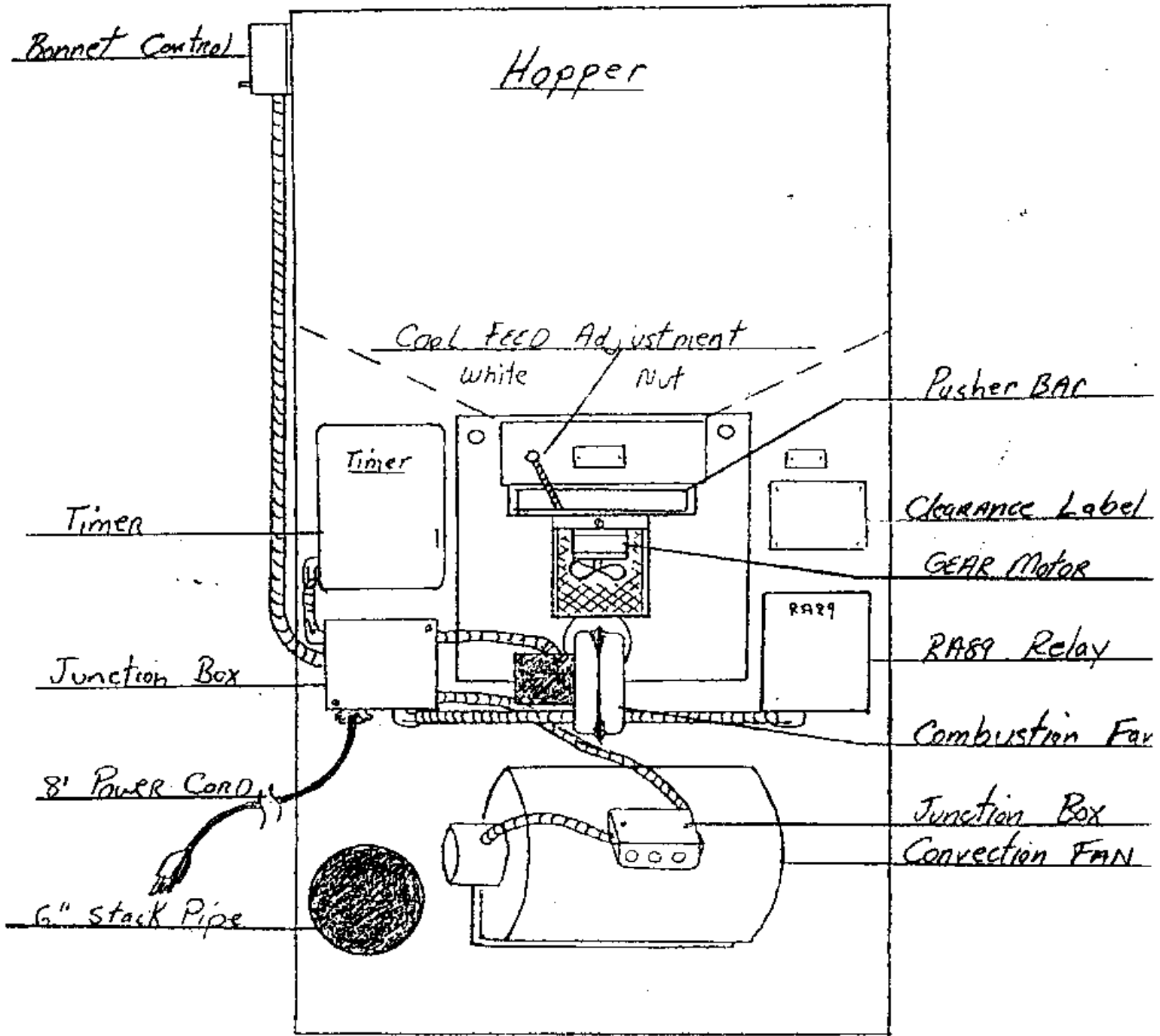

How to change a Gear Motor.

Step 1

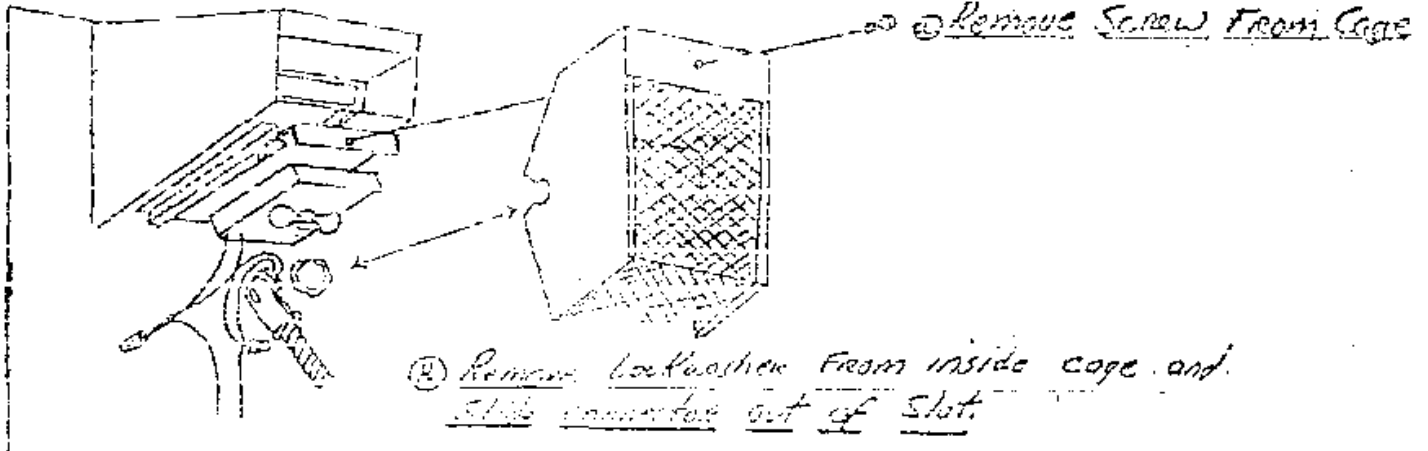

③ Remove wire nuts and disconnect gear motor wires.

Step 2

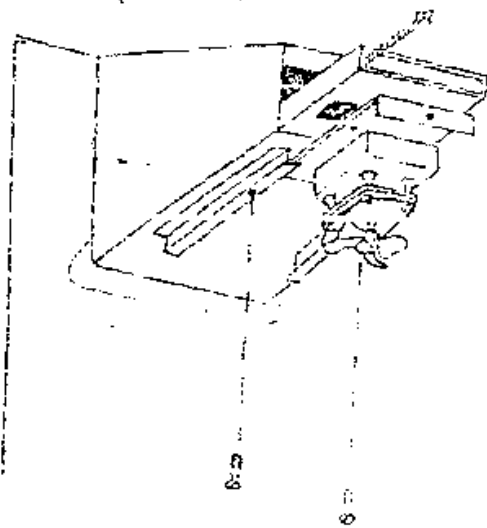

Step 3

Mounting Plate

⑤ Remove four screws from plate and take off motor.

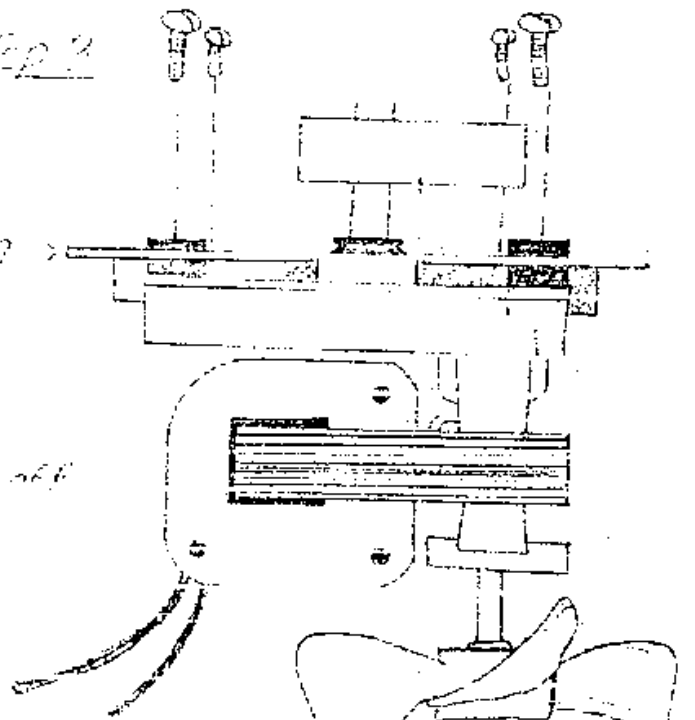

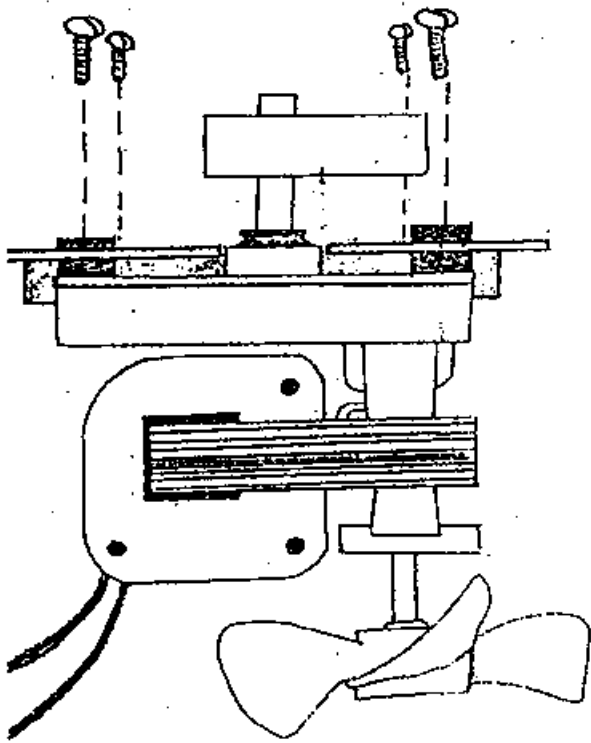

- ① Slide new motor onto plate
Tighten Four screws snug.

- ② Fit Corn into pushed Bar and slide
Both motor and pushed Bar into place.
 ③ Tighten two screws snug.

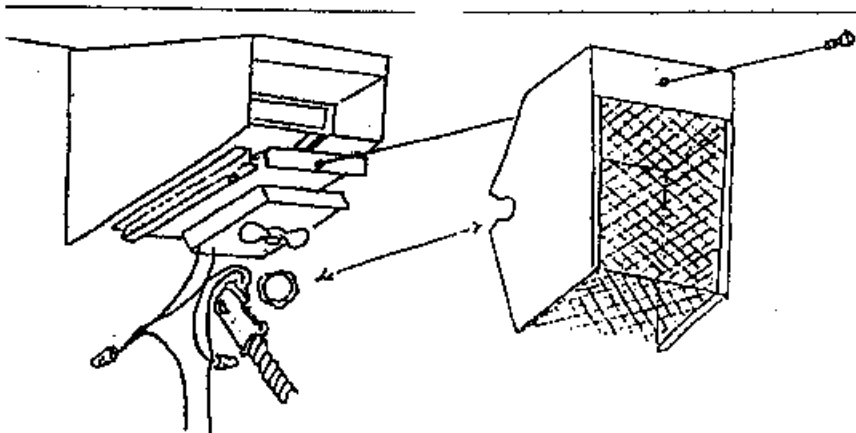
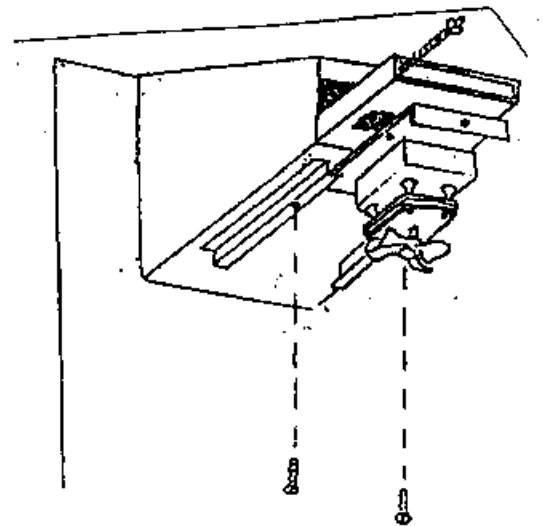

- ④ Make proper wire connections.
 ⑤ Slide cage back onto motor plate
and tighten screw.
 ⑥ Slide connector back onto cage
and tighten Lockwasher

TROUBLE SHOOTING GUIDE

1. Fire goes out
 - A. Increase coal feed, as necessary, to maintain approximately three inches of red burning coals on grate.
 - B. Raise heat sensor 10 to 20 points above present setting daily, until fire stays lit. Sensor control has one purpose TO MAINTAIN A FIRE, during periods of no demand by room thermostat. The number heat sensor is finally set at is irrelevant.
 - C. If timer is used instead of heat sensor, increase timing cycle by adding additional clips to increase running cycle of stoker unit.
2. Coal over side rails
 - A. Reduce coal feed.
 - B. Increase opening of combustion air shutter.
 - C. Check, with level, to be certain that hopper end of stove is plumb.
 - D. Sand grate and side rails smooth with emery cloth.
 - E. MIXing buckwheat coal with rice coal may help.
3. Gas smell

A-140 - A-90 models, clean heat exchanger, stove pipe and or chimney. Close combustion air shutter as necessary to eliminate gas smell.

Top vent, bottom vent and Econo stoves - clean top of stove, stove pipe, and or chimney. Close combustion air shutter as necessary

Hearth models - open ash door, remove ash pan, vacuum or brush out elbow at bottom rear of stove.

If problem persists, shut stove off, call your local dealer for assistance.
4. Stoker unit cycles too often
 - A. 416-4 Heat sensor has a fixed differential of 20 degrees, between turning on and off. Lower setting on dial 5 points per day. Being careful not to lower setting to the point where loss of fire results.
5. Stoker unit doesn't feed coal
 - A. Pusher bar may be jammed. Remove all coal from hopper and stoker unit. Work pusher bar inward and outward, not side ways. Pusher bar is free when it has a slight inward and outward movement.
 - B. Gear motor defective. Replace. Remove screw from black expanded metal cover. Disconnect wires on gear motor. Remove two screws from gear motor mounting bracket, place hand on gear motor, pull motor toward you. Remove old gear motor from mounting bracket, install new gear motor on mounting bracket. Place cam into hole in pusher bar, slide assembly into stoker unit. Tighten screws and reconnect wires.

5. Convection blower runs too often
 A. Convection blower will only run when internal air temperature reaches center pointer of fan limit switch. If blower runs too often during periods of no demand by thermostat, internal air temperature is too high. To cool stove off, lower setting on dial of heat sensor 5 points per day.
6. Convection blower runs constantly
 A. Pull white button on fan limit switch out for automatic operation.
7. Convection blower off too long
 A. Convection blower will only turn on when internal air temperature reaches center pointer in fan limit switch.
 1A Fire bed is too small - Increase coal feed until only two inches of ash remain on bottom of grate.
 2A Fire bed not burning hot - Increase opening of combustion air shutter. Clean under grate. Clean combustion air fan.
 3A Fire bed is too thick - Refer to #2
8. Fire lit but no heat
 If stoker unit only runs short cycles
 A. Loose or broken wires from thermostat to Honeywell Relay. Check connection on thermostat backplate to thermostat. If bottom two screws are loose, thermostat will not operate stoker.
 If stoker unit runs constantly
 Refer to 1A - 2A - 3A of #7
9. Stoker unit runs constantly
 Stoker unit can only run by demand of thermostat, heat sensor, or timer (timer not on most models)
 A. Disconnect wires from thermostat - if stoker shuts off, replace thermostat, or thermostat wire.
 B. Disconnect wires from 416-4 Heat sensor - if stoker unit shuts off, replace heat sensor
10. Convection blower not blowing hard
 A. Clean screen and fan blades on convection blower.
11. Stoker unit shuts off on Hi-Limit
 High limit pointer in fan limit switch is designed to shut stoker unit off, when internal air temperature reaches safety setting of 200 degrees. If internal air temperature stays on high reading, convection blower is not cooling stove off quickly enough. Clean screen on convection blower, fan blades on convection blower, or air filters (air filters on A-140, & A-90 models)

Not enough air through fire

- A. Fan blades on combustion motor dirty. Brush off.
- B. Accumulated flyash under grate. Remove combustion motor and clean.
- C. Holes blocked in grate. Open holes with 1/8" center punch.
- D. Combustion motor not running. Replace. To replace combustion motor, remove three nuts, disconnect wires, install new motor. Combustion motors on hearth model stoves are mounted with screws.

To clean under or replace grate

Remove all coal from hopper and stoker unit. Remove nut and bolt from bottom of grate. Tap grate in upward direction with hammer. Remove grate, clean off old furnace cement from grate and unit. Clean flyash from under grate. Smear furnace cement around top of grate and sides of grate down to where holes start. Place grate back into unit, and secure with nut and bolt.

Nylon cam melts

Under normal operating conditions, nylon cam will not melt. Melting of nylon cam can only be caused by a draft problem.

- A. A blockage in chimney, chimney connector, stove pipe, or stove. Inspect and clean.
- B. Excessive draft, caused by high chimney, large flue, or high winds. Clean and adjust barometric damper. (Set barometric damper with draft gauge) - To set barometric damper with draft gauge - Start fire, allow stove and chimney to warm up. Turn stoker unit off. Using a sheet metal plate, or equivalent, a little larger than ash door opening, drill a 17/64 hole in plate. Open ash door wide, hold plate over entire opening of ash door. Insert draft gauge in hole, and adjust barometric damper to obtain a draft reading of -.02.

To order parts

Should it become necessary to order a control, identify the number marked on the control before ordering. Controls are warranted for 1 year. The controls are date coded, the first two numbers indicate the year, second two numbers indicate week of year. Save your sales receipt for PROOF OF PURCHASE.

If you need to order a part on stoker unit, find the 1½" X 3" Keystoker label fastened to stoker unit body. The four or five digit number will be required to get proper replacement parts from your dealer.

SAFETY

THE BURNING OF ALL FOSSIL FUELS GENERATES CARBON MONOXIDE GASES. CARBON MONOXIDE GASES ARE TOXIC, CAN CAUSE SICKNESS, CAN BE FATAL.

To prevent toxic carbon monoxide gases from entering the home, certain precautions must be taken.

Ash tub must be emptied on a regular basis to prevent ashes from overflowing into ash pit area. Excessive ash accumulation may impede air flow to chimney, preventing gases to be drawn up chimney.

Fire door and ash door must be closed at all times during normal operation.

It is necessary to keep some coal in hopper while stove is in operation.

In most applications it is sufficient to clean stove and stove pipe twice during the heating season. However, under extreme weather conditions, or high demand on stove running periods, the stove and stove pipe may need more frequent cleaning. Clean as often as necessary.

CAUTION ASH PAN IS HOT - ALWAYS USE GLOVES TO REMOVE ASH PAN

Before removing ash pan, turn switch off, or pull power cord plug from 110V outlet. Open ash door. Use a good pair of gloves, to remove ash pan. Place ash pan on non-combustible surface. Slide an empty ash pan into stove. Close ash door. Turn switch on or plug power cord back into 110V outlet.

ON DIRECT VENT MODELS

After removing ash pan, using long brush supplied with stove. Reach brush straight back into 6" exhaust pipe and with a circular motion, sweep brush around inside of pipe. Sweep excess toward bottom of stove and remove or vacuum dust out of stove. This procedure may only be required once or twice a month during heating season. Place empty ash pan into stove and turn switch on or plug power cord into 110V outlet.

Fan blade and fan blade chamber may have to be cleaned several times during the heating season. (See cleaning instructions)

The 4" exhaust pipe going through outside wall of home should also be cleaned when fan chamber is being cleaned.

If 4" exhaust pipe is not going straight out through outside wall and 4" pipe is in a vertical position to access an area above outside grade, the 4" elbow is a likely location for dust to accumulate and restrict exhaust air flow to outside of home. A 4" tee may also be used in place of a 4" elbow. This will allow the bottom of tee to be used as a collection point (out of the flow of exhaust gases) providing an easier access for cleaning and less chance for restriction or blockage.

IT IS ESSENTIAL that every 4" pipe joint or connection be sealed with a high temperature silicone or equivalent. All adjustable joints on elbows must also be sealed with silicone. FAILURE TO SEAL ALL JOINTS could allow carbon monoxide to leak in to home.

STOVE CONTENTS

TT MODELS

Heat Control Models

Manual _____

Manuals _____

Carbon Monoxide
Tester _____

Carbon Monoxide
Tester _____

Glass Cleaner _____

Glass Cleaner _____

Charcoal _____

Charcoal _____

Thermostat _____

2-Handles & Bolts _____

2-Handles & Bolts _____

Brass Handle/Koker _____

Brass Handle/Koker _____

Brass Trim 90/105 _____

Brass Trim-90/105 _____

Clamp & Screw
BV & Koker _____

Clamp & Screw
BV & Koker _____

Damper
TV Only _____

Damper
TV Only _____

Top Plate
Stoves with Cut _____

Top Plate
Stoves with Cut _____

PACKED BY: _____