



The **Pine**
ANTHRACITE COAL STOVE
HF-75



OWNER'S MANUAL



Table of Contents

<u>Section 1:</u> Coal Heater Description.....	3
<u>Section 2:</u> Installation Materials.....	5
<u>Section 3:</u> Installation.....	7
<u>Section 4:</u> Operating Instructions.....	13
<u>Section 5:</u> Warranty Information.....	15
<u>Section 6:</u> Warranty Registration Form.....	19
<u>Section 7:</u> Satisfaction Survey.....	21

Contact Us

Reading Stove Company
P.O. Box 1200
200 Mahantongo Street
Pottsville, PA 17901
Phone: (570) 622-5150

Section 1: Coal Heater Description

A. E.P.A. Compliance Status: This manual describes the installation and operation of the Reading Stove Company Pine HF-75 Coal Stove. This heater is exempt from U.S. Environmental Protection Agency's particulate emissions standard and complies with Federal Regulations 40 C.F.R. 60.

This heater is only for burning anthracite coal. Use of any other solid fuel except for coal ignition purposes is a violation of federal law.

Tamper Warning: Modification of this heater from its original design and structure may be a violation of federal law and will void the warranty.

Fuel Selection: This heater is designed to burn Premium Reading Anthracite Company Chestnut or Pea-Sized Coal. Coal that is less than 1/2" diameter will fall through the grate openings. **Note: Pea-size passes over 9/16" and through 13/16"; Nut-size passes over 13/16" and through 1 5/8".**

B. THE HF-75 CUT-AWAY VIEW

1. PRIMARY AIR
2. ASH COLLECTION CHAMBER
3. ASH PAN (INSIDE)
4. SHAKER HANDLE
5. LOADING DOOR
6. 1400°F WINDOW (TRANSPARENT)
7. FLUE COLLAR

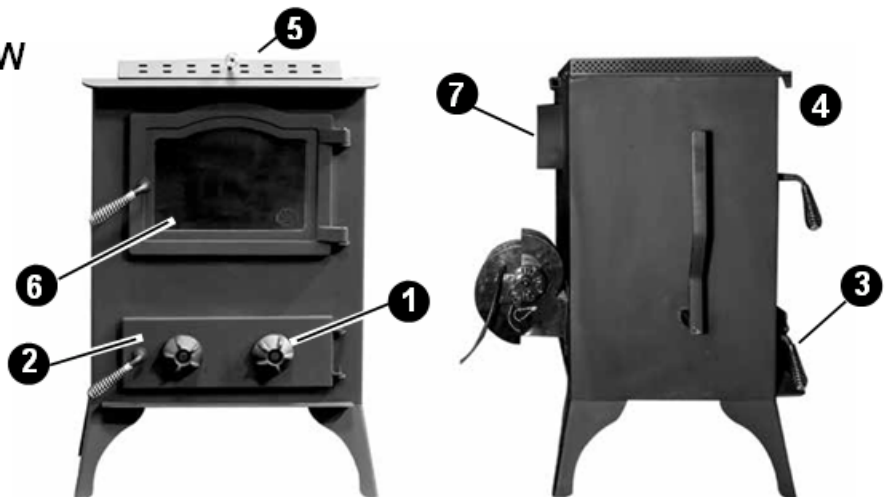

Basket: The sidewalls and back of the coal combustion chamber are constructed of durable fire-brick and supported with cast-iron liners. The floor of the coal combustion chamber is made of a heavy-duty cast-iron shaker grate. All of these components may be easily removed through the loading doors.

The combustion air is heated as it runs through cast-iron grate system of the heater and upward to the steel baffles. The air simultaneously cools the front panels of the coal combustion chamber before it is directed under the grate.

The grate does not overheat, because the combustion air continuously cools it. The same principle is applied to the front wall of the coal basket, which is constructed of steel, and 1400°F glass-ceramic.



Doors/Window: The Pine HF-75 has a large glass enclosed door for fire viewing. There is a second steel door on the bottom of the stove for ash removal. There is a steel dial on the ash removal door which may be adjusted to change the amount of combustion air entering the stove. To open either door, turn the handle clockwise and pull out; to close the doors, turn the handle to an 11 o'clock position and push in, returning the handle to a closed 8 o'clock position.

Doors must be closed during normal operation of the stove. The gaskets in the doors should be examined on a regular basis for wear and replaced when necessary. Maintaining proper door seals is important to ensure proper control of the stove. The stove should not be operated with an inadequate gasket seal, or with the ash removal door open, as a serious over-firing condition may result.

NOTE: The glass in your Pine HF-75 is manufactured to exact standards to withstand the high heat of an Anthracite Coal fire, but it is glass and as such must be treated with care. Do not slam the door shut or strike the glass with a heavy object. If the glass is broken, do not operate the stove until it has been replaced.

CAUTION: Substitution of any high-temp glasses, glass-ceramics, or other components in place of genuine Reading Stove Company parts may compromise the performance, the warranty, and even the safety of your stove.

Grates: The grate system of the Reading Stove Company Pine HF-75 consists of two (2) cast iron grates. The grates are linked together to operate in unison when the external shaker handle of the stove is moved. The grate system serves a dual purpose, the first of which supporting the coal while allowing air to flow through to the burning coals. The second purpose of the grate system is the removal of ash from the bottom of the coal bed while the stove is still under fire. The shaker lever should be moved back and forth in short choppy strokes causing the ashes to fall through into the ash pan.

C. Coal Combustion: A number of factors are critical to safe and efficient combustion. Each of the factors will be addressed independently in the paragraphs that follow. If any questions remain after you have studied this section, please do not hesitate to contact your local dealer or Reading Stove Company.

Draft: This term is defined as the vacuum generated within the chimney by your heating system. Your stove will operate best if you maintain a draft of .04 to .06 inches H₂O.

Excessive Draft: Excessive draft will make it difficult to control the heat output of your stove. Air will move so quickly through the system that combustion efficiency will be hindered and needless heat will exit the chimney. A barometric damper must be installed on the flue pipe of your stove.

Insufficient Draft: Insufficient draft will result in a loss of heat output and possibly some back-smoking, especially when the fueling door is open. Draft may be improved by increasing the height of the chimney, or, in many cases, by resizing the chimney liner to match the diameter of the stove.

Intermittent Draft or Down Draft: This type of draft is generally caused by wind patterns that are moving downward as they pass the chimney outlet. There are a number of chimney caps available that address that problem. Shared chimney liners should never be used.

The Coal Bed: The coal bed in an anthracite coal stove must be several inches deep to ensure that there is sufficient capture and radiation of heat to maintain combustion. It is also important that the coal bed is of constant thickness. A hole or thin area will allow combustion air to bypass the rest of the coal bed, and eventually the fire will go out. Do not add coal above the level of the fire brick or the steel portion of the coal combustion chamber in the front of the stove.

Shake Down of Ash: Shaking down of ash is required to maintain the flow of combustion air up through the coal bed. When the coal bed thins and darkens, it is an indication that the grate is covered with a thick layer of ash, and it is time to shake down. The shaking process also helps the hopper to discharge additional coal into the combustion chamber. Once sparks begin to shower down, stop shaking. Excessive shaking will waste fuel and add needless wear and tear to the grate system.

Section 2: Installation Materials

Barometric Damper: Reading Stove Company recommends that a barometric damper be installed in the chimney connector pipe. Maintaining the draft at a controlled constant minimizes the possibility of over-firing and improves the combustion efficiency.

The Field Model R-C, manufactured by Field Controls, Kinston, North Carolina 28501, is a preferred version, because it is easy to install and does not require a draft gauge for set up.

The six (six) inch Model R-C will fit in the side leg of a standard single wall black tee connector. (See Figure 6.1)

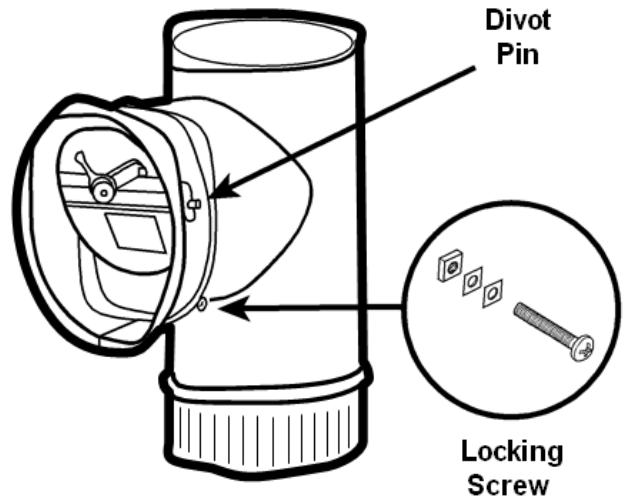

Fig. 6:1 Field Model R-C Barometric Damper

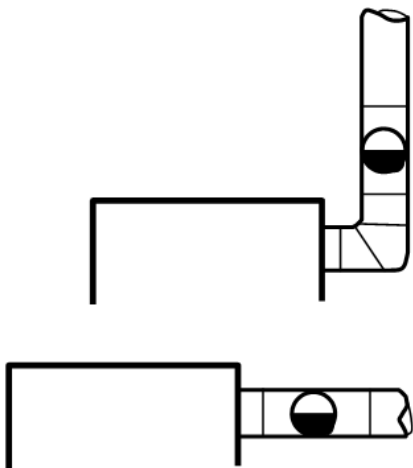

Fig. 6:2 Draft Control Placement Examples

The tee may be positioned anywhere within the stove to chimney connection. It may be installed vertical, horizontal Or sloping smoke pipe. However, it is critical at accurate calibration that the front edge of the side leg is straight up and

i.e.

down,

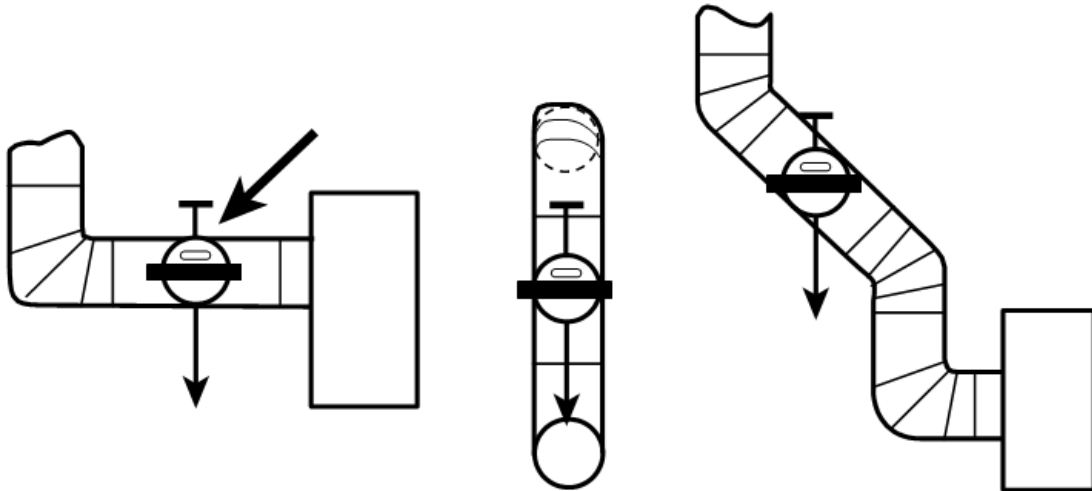

FIGURE 7:1 POSITIONING DRAFT CONTROL
 Black Tee Joint Stub opening must be Plumb (Perpendicular)
 Position Draft Control in Stub opening so it is Plumb and Level

perpendicular to the floor (See Figure 6.2 and 7.1).
 (Most efficient closest to the appliance).

Field also recommends that the opening of the tee should be pointed away from any nearby walls or obstructions.
 (See Figure 7.2)

Setting R-C Barometric Dampers: Turn the adjustment weight counter-clockwise to loosen, and slide it along the slotted channel to the proper position and tighten. The bracket is marked 2, 4, 6, and 8, which indicates the draft settings in one-hundredths of inches of water column.

LOCATE THE WEIGHT IN ALIGNMENT BETWEEN 4 and 6. Thus you will be limiting the maximum draft that the stove sees to approximately .05 inches H₂O.

Detailed and operating are supplied barometric Please review materials as information manual.

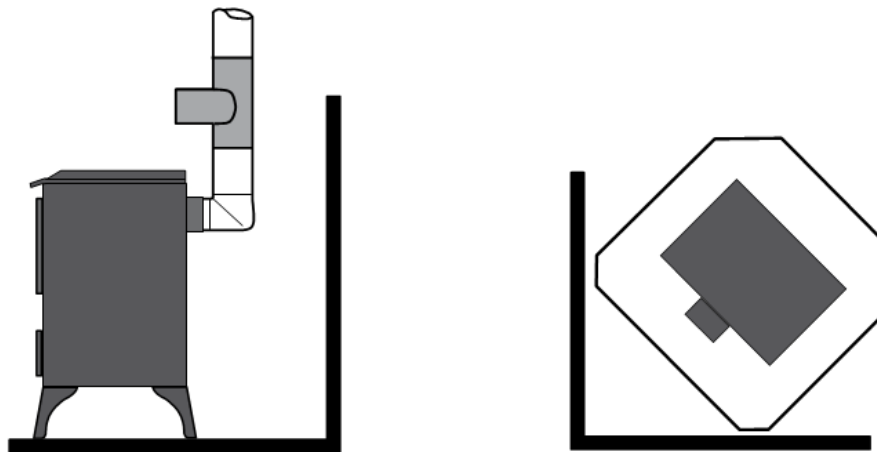

installation instructions with the damper. these well as the in this

FIGURE 7:2 POSITIONING BLACK TEE JOINT STUB OPENING
 Point Stub Opening of Black Tee Joint
 Away from Nearby Walls or Obstructions



Chimney Connector (also known as “flue pipe” or “stove pipe”): The chimney connector joins the stove to the chimney. It should be six (6) inches in diameter, carbon steel, and 24-gauge minimum.

Thimble: A manufactured or site-constructed device installed in combustible walls through which the chimney connector passes to the chimney. It is intended to keep walls from igniting.

Chimney: (See specifications on Pages 8-10) APPROVED MASONRY with at least 5/8” fire clay lining joined with refractory cement or other listed lining system suitable for use with coal stoves, or PREFABRICATED six (6) or eight (8) inch listed high temperature residential type and building heating appliance chimney. Components required by manufacturers for installation such as the chimney support base, fire stop (as appropriate), attic insulation shield, insulated tee, etc., are necessary to assure a safe chimney installation. Use only components manufactured for the chimney.

Floor Protector: ¼” mineral board or equivalent. Measurements: Eight (8) inches beyond the sides and back; eighteen (18) inches beyond the front. Total Dimensions: 40” x 45” or larger (**Must be fire retardant material**).

CAUTION: Avoid Fire – Maintain the designated clearance distance to combustibles. Insulation must not touch the chimney. There must be the designated air space clearance around the chimney. This air space around a chimney is necessary to allow natural heat removal from the area. Insulation in this space will cause a heat build-up which may ignite wood framing.

Section 3: Installation

CAUTION: If this stove is not properly installed, a house fire may result. For your safety, follow the installation directions. Contact your local building or fire official about restrictions and installation inspection requirements in your area. Check your local building code.

Please read this entire manual before you install and use your new stove. Failure to follow instructions may result in property damage, bodily injury, or even death.

A. Locating Your Stove: When locating your stove, consider safety, convenience, traffic flow, and the fact that the stove will need a chimney and chimney connector. For safety, and to avoid drafts, avoid locations close to an exit.

Your stove should be located away from doors and hallways, and in an open area to allow for necessary clearances. **MINIMUM CLEARANCES SHOWN IN FIGURES 9.1 and 10.1 ARE TO PREVENT WALLS AND CEILINGS FROM CATING FIRE.**

Keep furniture, drapes, curtains, wood, paper, and other combustibles far away from the stove. Never install the stove in locations where gasoline, kerosene, charcoal lighter, or any other flammable liquids are used or stored.

DO NOT INSTALL THIS STOVE IN A MOBILE HOME.

Figure 9.1

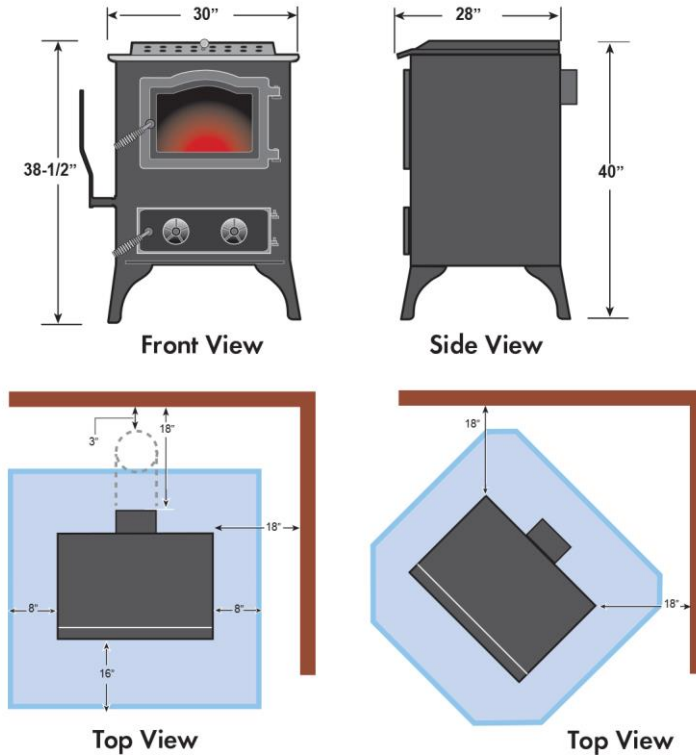

Figure 10.1

PREVENT HOUSE FIRES
 INSTALL AND USE ONLY IN ACCORDANCE WITH THE
 MANUFACTURER'S INSTRUCTIONS AND LOCAL BUILDING CODES
READING STOVE COMPANY
 POTTSVILLE, PA 17901
 1-800-654-7792

MODEL: PINE HF-75 COAL STOVE SERIAL N^o **P0001**

U.S. ENVIRONMENTAL PROTECTION AGENCY
 THIS HEATER IS ONLY FOR BURNING ANTHRACITE CHESTNUT, OR PEA COAL. USE OF ANY
 OTHER SOLID FUEL EXCEPT FOR COAL IGNITION PURPOSES IS A VIOLATION OF FEDERAL LAW.
 GUARDIAN FIRE TESTING LABORATORIES, INC. BUFFALO, NY 14216

TESTED 8/14 TO ANSI/UL 1482, ULC-S627, ETLM 78-1
 CHIMNEY TYPE: MINIMUM 6 INCH DIAMETER APPROVED LOW HEAT RESIDENTIAL TYPE ALL FUEL. - CHIMNEY
 CONNECTOR: 6 INCH DIAMETER 24 GAUGE BLUE OR BLACK STEEL. INSTALL AT LEAST 18 INCHES FROM CEILING.
 SPECIAL METHODS ARE REQUIRED WHEN PASSING THROUGH A WALL OR CEILING. SEE INSTRUCTIONS AND
 BUILDING CODES.

INSTALL WITH MINIMUM CLEARANCE TO WALL AS SHOWN (IN INCHES) **FREESTANDING MODE**

REAR WALL
SIDE WALL
STOVE
FRONT

CORNER INSTALLATION
STOVE
FRONT

FLOOR PROTECTOR
STOVE
FRONT
USE APPROVED FLOOR PROTECTOR

CONTACT YOUR LOCAL BUILDING OR FIRE OFFICIALS ABOUT
 RESTRICTIONS AND INSTALLATION INSPECTION IN YOUR AREA

B. Venting System: The venting system consists of a chimney connector and a chimney, these get extremely hot during use. To protect against the possibility of a house fire, the chimney connector and chimney must be properly installed and maintained. A thimble must be used when a connection is made through a combustible wall to a chimney. A chimney support package must be used when a connection is made through the ceiling to a prefabricated chimney. These accessories are necessary to provide safe clearances to combustible wall and ceiling material.

C. Chimney Connector: The chimney connector must be six (6) inches in diameter, 24-gauge minimum carbon steel. Do not use aluminum or galvanized steel. They cannot properly withstand the extreme temperatures of a coal fire. Do not use chimney connector pipe as a chimney. You must connect your stove to a chimney comparable to those illustrated in this manual. Chimney connector sections must be attached to the stove and to each other with the crimped end toward the stove (See Figure 10.2). All joints should be secured with three (3) sheet metal screws. For proper operation, the chimney connector should be as short as possible. Horizontal lengths of chimney connector should have an upward slope from the stove of 1/4" per foot. Maintain eighteen (18) inch clearances between the chimney connector and the wall and ceiling unless a wall protection system is installed.

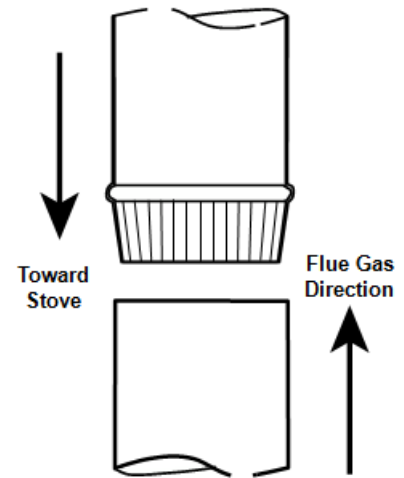

Fig. 10:2 Chimney Connector Sections

D. Connection to a Masonry Chimney:

1. Chimney: Should the stove be connected to a masonry chimney, the chimney should be examined for cracks, loose mortar, other signs of deterioration, and blockage. The stove should not be installed until it is determined that the chimney is safe for use. The size of the flue should be checked to determine that it is not too large for the stove. For this stove, the flue should be no larger than twelve (12) inches x twelve (12) inches or twelve (12) inches in diameter. (Eight (8) inches x Eight (8) inches or Six (6) inches x Six (6) inches in diameter is recommended.) The internal cross-section of the chimney must be at least 28 inches. The chimney should also be checked to assure it meets the minimum standards of the National Fire Protection Association (NFPA) Standard 211.

2. Thimble: A thimble must be used when the connection from the stove is made through a combustible wall to a masonry chimney. There are several methods to use for connection through a combustible wall, two (2) of which are illustrated in this manual. Local building authorities may be consulted or NFPA 211 may be used for additional methods of chimney connection.

Also, listed prefabricated metal thimbles can be bought for use with coal stoves. The manufacturer's installation instructions from the thimbles must be strictly followed to assure the safety of the system. Be sure to maintain the designated clearance to combustible materials.



E. Connection to a Masonry Fireplace: There are several kits available to connect the stove to a masonry fireplace. Look for a listed kit. The kit is an adapter, which is installed at the location of the fireplace damper. The existing damper may have to be removed to allow installation of the kit. The key points of this type of stove connection are that the connector pipe must extend up the chimney above where the fire clay liner starts, and the areas of the kit installation and connector penetration should fit tightly and be sealed with high temperature furnace cement unless the kit's instructions state otherwise. The tight fitting installation aids the proper draw of the chimney.

F. Connection to a Metal Prefabricated Chimney: When a metal prefabricated chimney is used, the manufacturer's installation instructions must be followed precisely. You must also purchase (from the same manufacturer) and install the ceiling support package or wall pass through and "T"-section package, fire stops (when needed), insulation shield, roof flashing, chimney cap, etc. Maintain the proper clearance to the structure as recommended by the manufacturer. This clearance is usually a minimum of two (2) inches, although it may vary by manufacturer or for certain components.

There are two methods of metal chimney installation. One method is to install the chimney inside the residence through the ceiling and the roof. (See Figures 12.1 and 12.2). The other method is to install an exterior chimney that runs up the outside of the residence. (See Figures 13.1 and 13.2). The components illustrated may not look exactly like the system you purchase, but they demonstrate the basic components you will need for a proper and safe installation.

The chimney must be the required height above the roof or other obstruction for safety and for proper draft operation. The requirement is that the chimney must be at least three (3) feet higher than the highest point where it passes through the roof and at least two (2) feet higher than the highest part of the roof or structure that is within ten (10) feet of the chimney, measured horizontally.

NOTE: Follow the manufacturer's installation instructions and maintain the manufacturer's specified clearance distances.

Fig. 12:1
Metal Chimney Installation
through the Ceiling and Roof

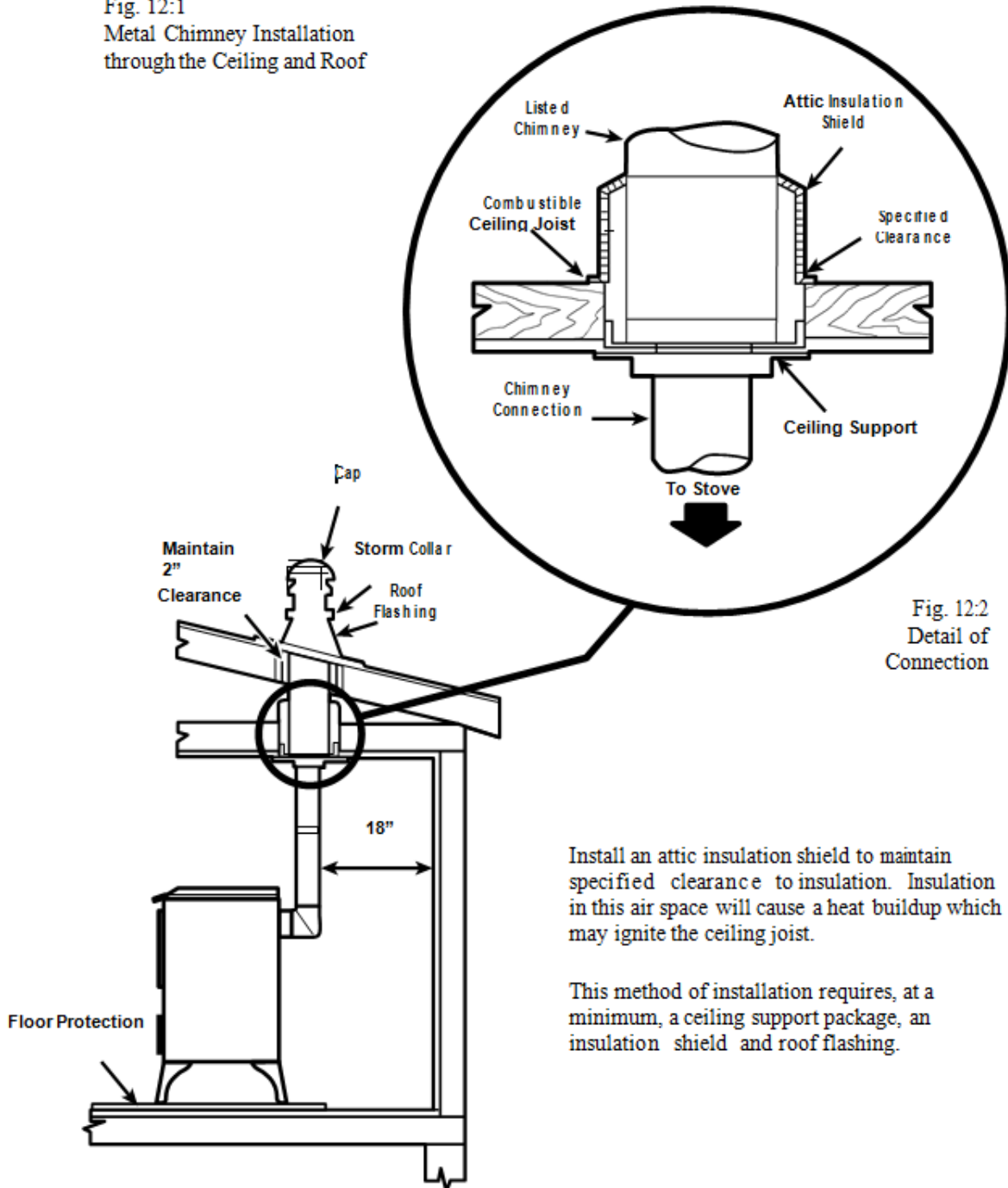

Fig. 13:1
Metal Chimney Installation
through the Ceiling and Roof

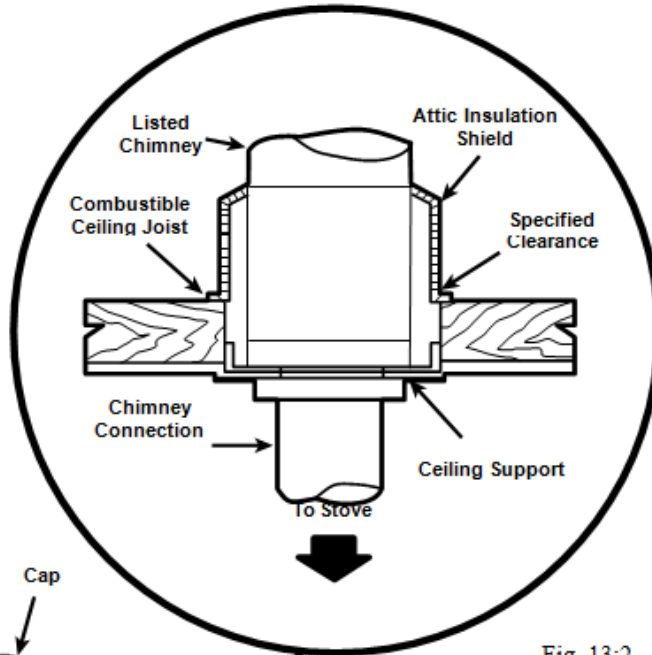
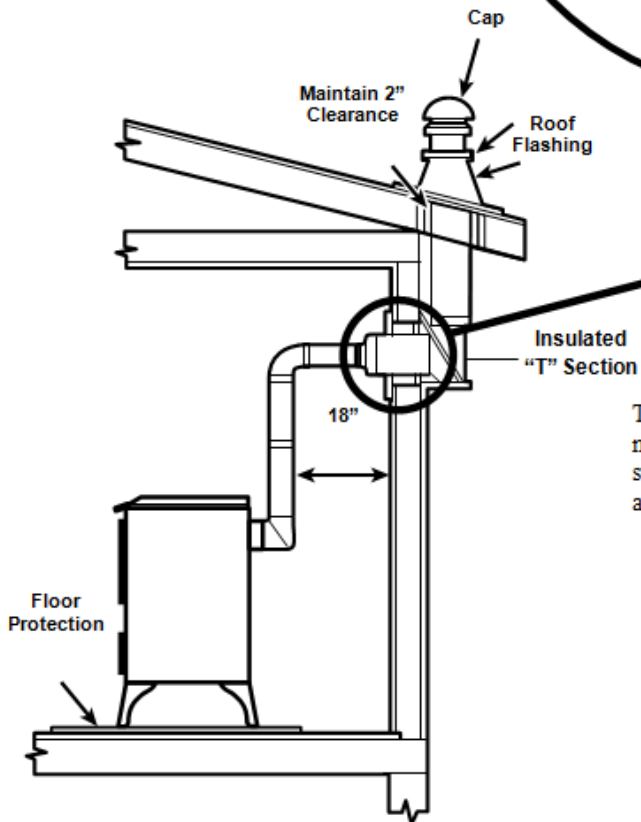

Fig. 13:2
Detail of
Connection



This method of installation requires at a minimum a wall pass through devise, a wall support package and insulated "T" section and roof flashing.



Section 4: Operating Instructions

A. The Controls: The heat output or rate of combustion is controlled by the primary combustion air controls. When the dial is turned all the way to the left, the setting is “high burn”. When the dial is turned all the way to the right, allowing just the slightest opening, the setting is “low burn”.

1. The Shaker Tool – Each Pine HF-75 comes with a tool which attaches to a fitting on the side of the base of the stove and is used to shake the grate to remove ashes.

2. The Barometric Damper – The draft in the chimney will change depending on how cold it is outdoors, the burn rate of the stove, and wind conditions. A barometric damper is basically a vacuum relief valve for the chimney system. It is considered good practice to install one in all coal burning applications.

B. Starting a Coal Fire:

1. Open the loading door on the top of your stove
2. Put a single layer of match-light charcoal on the grate
3. Open the air control to high burn
4. Light the charcoal with a long match or a rolled up piece of newspaper
5. Close the loading door
6. Allow the coal to burn until it is glowing (Approx. 10-15 minutes)
7. Slowly open the loading door; keeping your face and body clear of the opening in the event of any combustible gases that may have accumulated
8. Gently sprinkle a single layer of coal over the bed of the burning charcoal and close the loading door
9. Once the coal is burning, add more layers of coal through the hopper lid without exceeding maximum capacity.
10. Close the loading door and reset the primary air control for the desired heat output.

C. Refueling:

WARNING: It is recommended that you wear gloves whenever working with a hot stove.

With Hopper –

1. Turn the air control dial to the left (counter clockwise), allowing more air flow – “high setting.”
2. Gently shake down the dead ash, once sparks begin to shower down, stop shaking.
3. Open the loading door on the top of your stove.
4. Add coal into the hopper, not to exceed the capacity of the hopper.
5. Close loading door on the top of your stove.
6. Allow the coal to burn (approx. 5-10 minutes).
7. Reset the primary air control for the desired heat output.

Without Hopper -

1. Turn the air control dial to the left (counter clockwise), allowing more air flow – “high setting.”
2. Gently shake down the dead ash, once sparks begin to shower down, stop shaking.
3. Open the glass loading door turning the handle clockwise. CAUTION: Keep your face and body clear of the opening.
4. Add additional coal to the coal bed, being careful not to exceed the level of the fire brick.
5. Close the loading door and reset the primary air control for the desired heat output.

D. Over-Firing:

WARNING: DO NOT over-fire this heater. Attempts to achieve heat output rates that exceed heater design specifications can result in permanent damage to the heater. Never open the ash door to accelerate burn.

Using flammable liquids, wood, or burning trash in the stove may result in over-firing. If the chimney connector or stove glows red or, even worse, white, the stove is over-fired. This condition may possibly cause a house fire. *If you over-fire, immediately close the stove damper and doors to reduce the air supply to the fire.*

E. Understanding Draft: Draft is the force which moves air from the appliance up through the chimney, the amount of draft in your chimney depends on the length of the chimney, local geography, nearby obstructions, and other factors. Too much draft may cause excessive temperatures in the appliance. Inadequate draft may cause back puffing into the room and “plugging” of the chimney. Inadequate draft will cause the appliance to leak smoke into the room through the appliance and chimney connector joints. An uncontrollable burn or a glowing red stove part or chimney connector indicates excessive draft.

F. Ash Removal from the Stove:

1. Open the ash removal door, turning the handle clockwise
2. Using a pair of gloves, carefully remove the ash pan
3. Before leaving the stove, close and secure the ash cleanout door
4. Carry the ash pan out of the house. Remember it contains hot ashes and most likely some red hot coals Place the ashes in a metal container away from combustibles
5. Re-open the ash clean out door and place the ash pan back into the stove, close and secure the ash door

G. Grates: This stove is designed to be operated ONLY with the grate system, including firebricks in place. The grate is air-cooled by the primary combustion air. Failure to remove the ashes before they accumulate to the depth that they are near or touching the bottom of the grate may cause the grate to overheat.

The firebrick walls of the coal combustion chamber are designed to hold the burning embers away from the outer walls of the stove. Operating the stove with the firebricks removed may overheat parts of the stove and may subsequently result in unsafe temperatures to surrounding combustibles. Reading Stove Company replacement parts are available either through your stove dealer or directly from Reading Stove Company.



Section 5: Warranty Information

The manufacturer extends the following warranties to the original owner from the date of purchase. This warranty is non-enforceable if the enclosed warranty page is not returned within 30 days from the date of purchase.

Reading Stove Company warrants its products to be free from defects in material or workmanship, in normal use and service, for four (4) years from the date of sales invoice for residential use, one (1) year for commercial use. There is a four (4) year warranty on the body of the stove and a one (1) year warranty on all electrical components.

The warranty above constitutes the entire warranty with respect to Reading Stove Company products.

READING STOVE COMPANY MAKES NO OTHER WARRANTY, EXPRESS OR IMPLIED, INCLUDING “ANY” WARRANTY OR MERCHANTABILITY, OR WARRANTY OF FITNESS FOR A PARTICULAR PURPOSE. No employees, agent, dealer, or other person is authorized to give any warranty on behalf of Reading Stove Company. This warranty does not apply if the product has been altered in any way after leaving the factory. Reading Stove Company assumes no liability for resultant damages of any kind arising from the use of its products. In addition, the manufacturer shall be held free and harmless from liability from damage to property related to the operation, proper or improper, of the equipment. **THERE ARE NO WARRANTIES WHICH EXTEND BEYOND THE DESCRIPTION ON THE FACE HEREOF.**

These warranties apply only if the device is installed and operated as recommended in this Owner’s Manual.

These warranties will not apply if damage is caused by abuse, accident, improper installation, negligence, or use beyond rated capacity.

SERVICE LABOR RESPONSIBILITY: In furnishing replacement parts, Reading Stove Company assumes no responsibility for any labor expenses, for service removal or reinstallation.

If defective in material or workmanship, and if removed by the owner within the warranty period, Reading Stove Company will, at its opinion, repair or replace the product as described below.

HOW TO MAKE A CLAIM: Any claim under this warranty should be made to the dealer from whom this appliance was purchased. The dealer will require the model and serial numbers, the date of purchase, plus a simple explanation of the nature of the defect. The dealer will then contact the manufacturer.

SHIPPING COSTS: The transportation charges are as follows:

1. Customer prepays freight back to factory
2. Reading Stove Company prepays the repaired or replaced stove freight charges

NOTE: Prior approval by phone or in writing shall be made before shipping entire unit to manufacturer.

THIS WARRANTY IS LIMITED TO DEFECTIVE PARTS—REPAIR AND/OR REPLACEMENT AT OUR OPTION AND EXCLUDES ANY INCIDENTAL AND CONSEQUENTIAL DAMAGES CONNECTED THEREWITH.



WARRANTY EXCLUSIONS: (1) Labor (2) Door Packing (Gasket) (3) Paint (4) Glass (5) Hopper (coal) (6) Ash Pan (7) Damage Due to Natural Disasters, War, or Terrorism (8) Rust (9) Nickel Finish

PLEASE READ THE LITERATURE BY THE MANUFACTURER FOR THE VARIOUS ACCESSORY DEVICES. THESE DEVICES ARE UNDER **WARRANTY BY THE MANUFACTURER**, NOT BY READING STOVE COMPANY. FURTHERMORE, THESE ACCESSORY DEVICES MUST BE INSTALLED AND USED ACCORDING TO THE RECOMMENDATIONS OF THE MANUFACTURER.

REMEDIES: The remedies set forth herein are exclusive, and the liability of seller with respect to any contract or sale or anything done in connection therewith, whether in contract, in tort, under warranty, or otherwise, shall not, except as herein expressly provided, exceed the price of the equipment of part of which such liability is based.

CLARIFY: The above represents the complete warranty which is given in connection with stoves manufactured by Reading Stove Company. No other commitments, verbal or otherwise, shall apply except by a written addendum to this warranty.

All liability for any consequential damages for breach of any written or implied warranty is disclaimed and excluded here from. Some states do not allow the exclusion or limitations of incidental or consequential damages, so the above limitations or exclusions may not apply. This warranty gives the consumer specific legal rights, there may be other rights that vary from state to state.



Don't forget to stock up on Mother Nature's Clean Coal ®

Reading Stove Company's sister company, Reading Anthracite Company, is an anthracite mining, processing and sales organization in Pottsville, Pennsylvania that provides fuel for coal stoves.

The Pine HF-75 Coal Stove is designed to burn Premium Reading Anthracite Company Chestnut or Pea-Sized Coal.

See your local dealer or coal supplier to purchase reliable coal from the Famous Reading Anthracite today! If they don't carry our product, ask them to!

For further information regarding Reading Anthracite Company, please visit www.ReadingAnthracite.com or call (570) 622-5150.



This Page
Intentionally Left Blank

Section 6: Warranty Registration Form

Pine HF-75

Purchased by (Name): _____

Address: _____

City: _____ State: _____ Zip: _____

Telephone: _____

Email: (Optional) _____

DEALER INFORMATION

Purchased from (Dealer): _____

Address: _____

City: _____ State: _____ Zip: _____

UNIT INFORMATION

Purchase Date: _____

Serial Number: _____

**This registration information must be on file for the warranty to be valid.
Please mail this information within thirty (30) days from the date of purchase.**

Mail to:

Reading Stove Company
P.O. Box 1200
Pottsville, PA 17901

This Page
Intentionally Left Blank

Section 7: Satisfaction Survey

In an effort to improve our customer service and products, please fill out the below survey and return it *with* your **Warranty Registration Form to Reading Stove Company, P.O. Box 1200, Pottsville, PA 17901 within thirty (30) days from the date of purchase.**

1. How did you learn about this product?

Provide as much info as possible -

- Television _____
- Radio _____
- Newspaper _____
- Internet _____
- YellowPages _____
- Word of Mouth _____

2. Overall, how satisfied are you with this product?

- Very Satisfied
- Satisfied
- Neutral
- Dissatisfied
- Very Dissatisfied

Comments: _____

3. What impressed you most about the product?

- Quality of Craftsmanship
- Price
- Customer Service
- Features & Benefits
- Fuel Cost Savings
- Ease of Use
- Design

Comments: _____

4. Rate your overall opinion about the quality of this product.

- Very High Quality
- High Quality
- Average
- Low Quality
- Very Low Quality

Comments: _____

5. Will this product be used as a supplemental heating source?

- No
- Yes

If yes, in addition to what? _____

6. Will this product *replace* another type of heating source?

- Wood
- Wood Pellets
- Electricity
- Propane
- Natural Gas
- Oil

7. How would you rate your Reading Stove Company Authorized Dealer?

- Excellent
- Very Good
- Good
- Average
- Poor

8. Would you recommend our product to others?

- Yes
- Probably
- Not Sure
- No

Comments: _____

9. Additional Comments

May we use your first name, last initial and City, State coupled with any part of this survey as a testimonial to be featured on future marketing materials?

- No
- Yes

Thank you!